

NOTES:

- 1) WELDING CONFORMS TO CSA W59-1989
- 2) PLUMBNESS TOLERANCE:  
10mm:1000mm V TO A MAX. OF 25mm H
- 3) PAINTED WITH RED OXIDE PRIMER
- 4) NORMALLY STOCKED IN 1.52 M TO 2.44 M LENGTHS
- 5) SEE DWG. NO. VBK-3 FOR OPERATING KEY

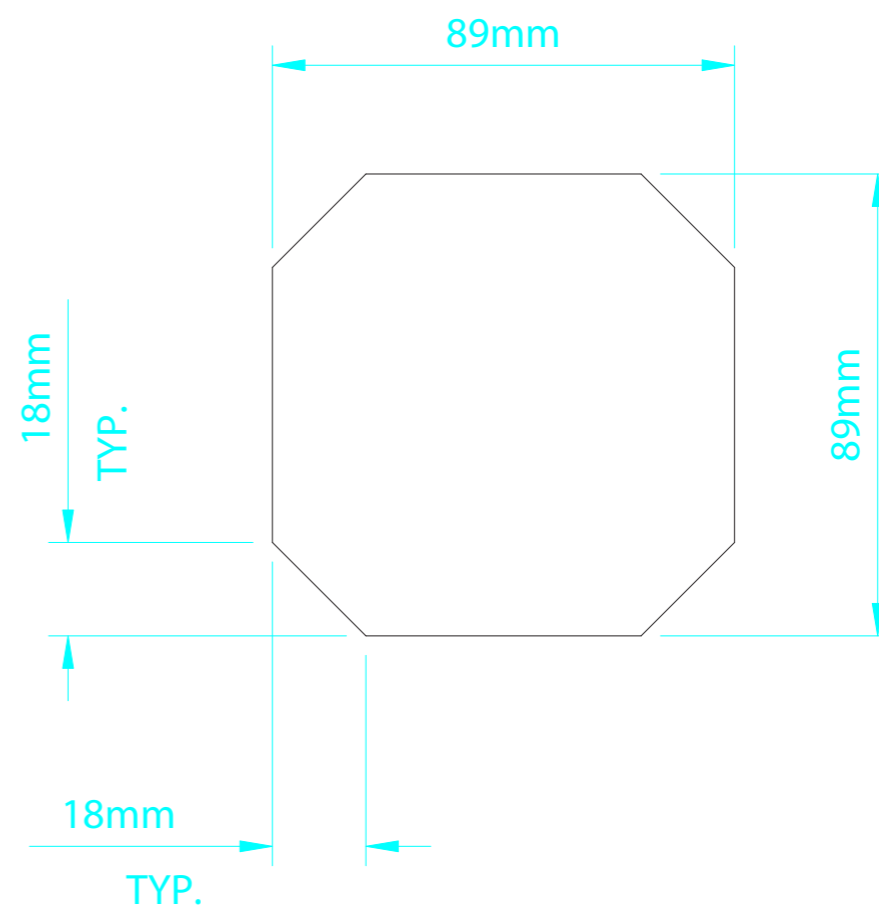
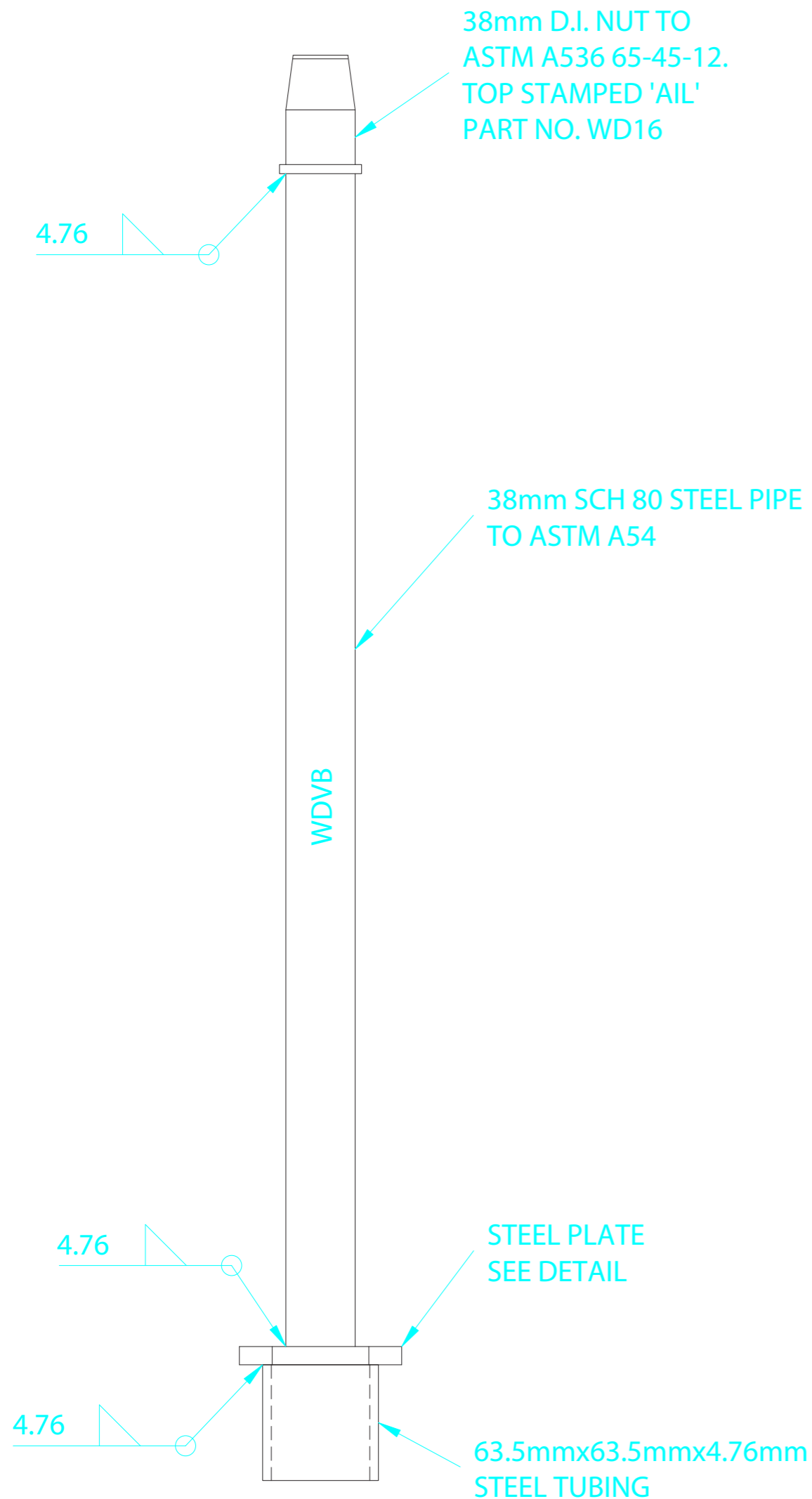

10mm STEEL PLATE  
TO CSA G40.21 (44W)

**VALVE SPINDLE  
WINNIPEG STANDARD**



1036 Waverley Street  
Winnipeg Manitoba Canada R3T 0P3  
P 204 896 1333 F 204 896 6969

APP'D BY: <b>WDP</b>	DATE: <b>08/06/02</b>
SCALE: <b>N.T.S.</b>	REV. NO: <b>00</b>
DWG. NO: <b>VBS-1</b>	