

TECHNICAL SPECIFICATION

Royal Seal™ Gasketed Sewer Pipe SDR 35

SCOPE

This specification covers the requirements for PVC (polyvinyl chloride) gravity sewer pipes with integral locked-in gasket bell and spigot joints. Nominal sizes 4" to 27" are manufactured to meet the requirements of the American Society for Testing and Materials (ASTM) standard D3034 (4-15") and F679 (18-27") and are certified to Canadian Standards Association (CSA) Standard B182.2 and Bureau de Normalisation du Quebec (BNQ) NQ 3624-130 (4-6") and NQ3624-135 (8-27").

MATERIALS

The pipe is manufactured from virgin PVC compound meeting the cell classification requirements of 12364 as defined by the American Society of Testing and Materials (ASTM) Standard D1784: *Standard Specification for Rigid PVC Compounds and CPVC Compounds*.

When available, Royal uses reworked PVC material from Royal pipe production, in accordance with Clause 4.1.3 of CSA B181.0, ASTM D3034 and F679 and BNQ NQ 3624-130/135. The supply of this type of rework material is not consistent, therefore Royal cannot guarantee the exact recycled content of any one product.

MARKING

Pipe markings are as specified in CSA B182.2, BNQ NQ 3624-130; and ASTM D3034 and F679.

PIPE

The pipe is manufactured for use in gravity flow sanitary and storm sewer. The pipe is produced with a wall thickness corresponding to the dimension ratio of SDR 35, with a pipe stiffness value of minimum 46 psi (320 kPa) when tested in accordance with ASTM D3034 and D2412, *Standard Test Method for Determination of External Loading*. Standard length of pipe is 4.0 m or 14 ft plus the bell length.

GASKETS

The pipe utilizes a double seal locked-in gasket system (DSLII) design which meets the requirements of ASTM D3212, *Standard Specifications for Joints for Drain and Sewer Plastic Pipes Using Flexible Elastomeric Seals*. The gaskets are reinforced with a steel band and conform to the requirements of ASTM F477: *Standard Specification for Elastomeric Seals (Gaskets) for Joining Plastic Pipe*. The standard gaskets are manufactured from Butadiene Styrene rubber. For specific purposes, Nitrile (NBR) gaskets can be substituted with this pipe. The DSLII design is used with both of these materials.

TEST REQUIREMENTS

Quality testing is as per Royal's Quality Assurance program and in accordance with CSA B182.2 and ASTM D3034 and F679.

PIPE DIMENSIONS

Nominal Size mm (in)	Outside Diameter (OD) mm (in)	Wall Thickness (t) mm (in)	Average Bell Depth (BD) mm (in)	Pipe Length (L) Plus Bell m
100 (4)	106.8-107.2 (4.206-4.224)	3.1-3.4 (0.122-0.135)	89 (3.5)	4.0
135 (5)	143.0-143.5 (5.630-5.650)	4.1-4.6 (0.161-0.180)	102 (4)	4.0
150 (6)	159.1-159.7 (6.264-6.286)	4.6-5.1 (0.181-0.201)	108 (4.25)	4.0
200 (8)	213.1-213.7 (8.388-8.412)	6.1-6.7 (0.240-0.266)	140 (5.5)	4.0
250 (10)	266.3-267.1 (10.484-10.516)	7.6-8.4 (0.300-0.333)	165 (6.5)	4.0
300 (12)	317.1-317.9 (12.485-12.515)	9.1-10.1 (0.360-0.399)	184 (7.25)	4.0
375 (15)	388.0-389.2 (15.277-15.323)	11.1-12.3 (0.437-0.485)	190 (7.5)	4.0
450 (18)	474.3-475.7 (18.673-18.728)	13.6-15.1 (0.534-0.593)	241 (9.5)	4.0
525 (21)	559.2-560.8 (22.014-22.080)	16.0-17.8 (0.632-0.702)	260 (10.25)	4.0
600 (24)	629.1-630.9 (24.766-24.840)	18.0-20.0 (0.711-0.789)	279 (11.0)	4.0
675 (27)	708.9-711.0 (27.911-27.994)	20.3-22.6 (0.801-0.889)	305 (12.0)	4.0

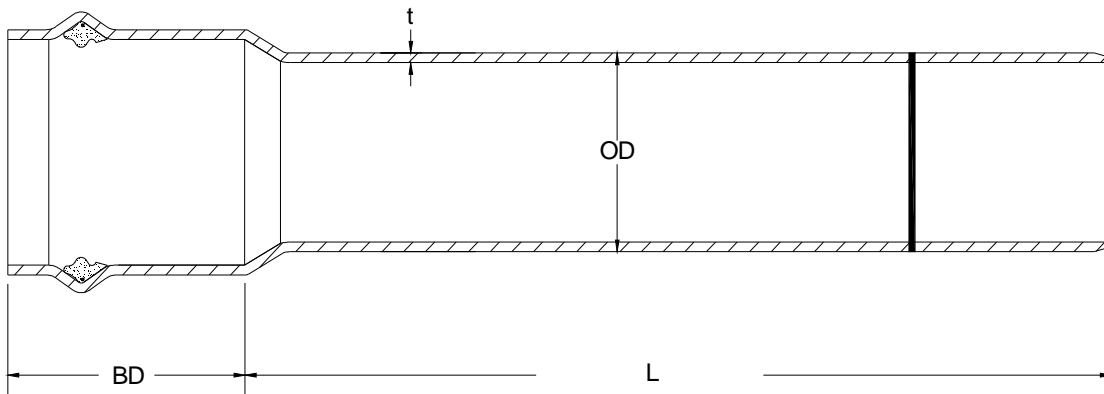

OPTIONAL PERFORATIONS

It is possible to perforate the finished pipe product. The standard perforation pattern consists of 2 rows of 1/2" diameter holes, 120 degrees apart, on 6" centres, as shown in the sketch below.

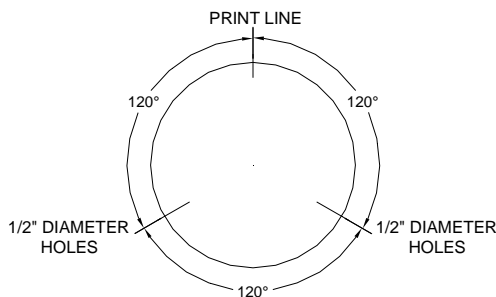

1/2" Diameter Holes-6" Spacing