

PROJECT
OWNER
CONTRACTOR
DISTRIBUTOR
CONSULTANT

350mm - 500mm FLANGED RW GATE VALVE WITH SPUR GEAR

F6102 SG

FUSION EPOXY - NSF 61 AND AWWA C550

**CLOW CANADA**

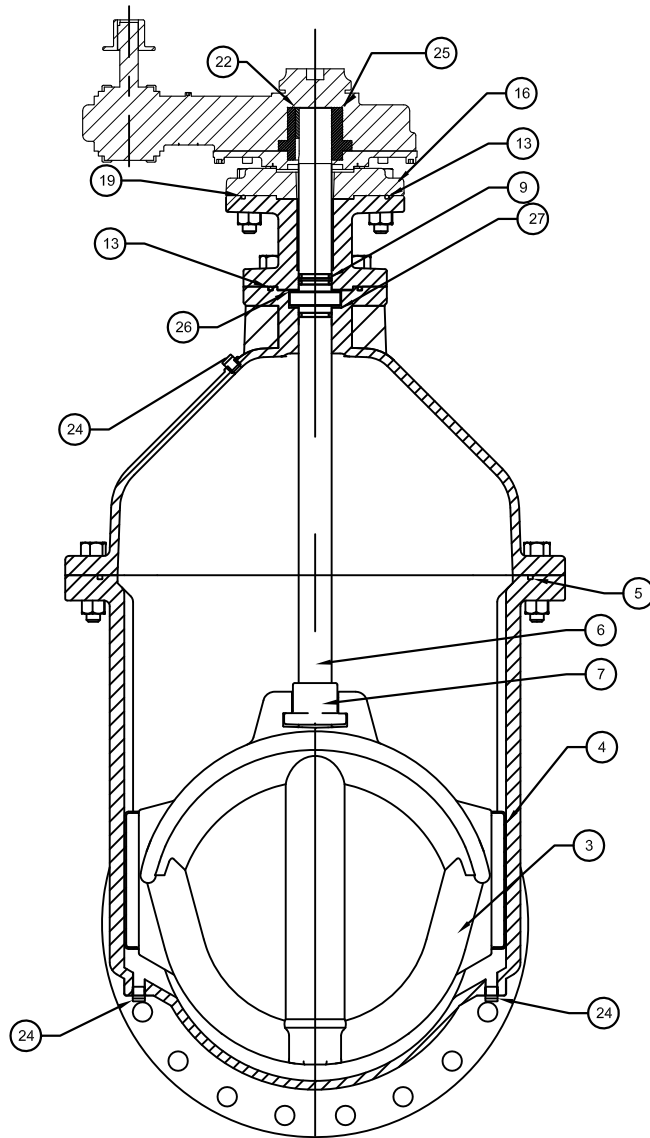
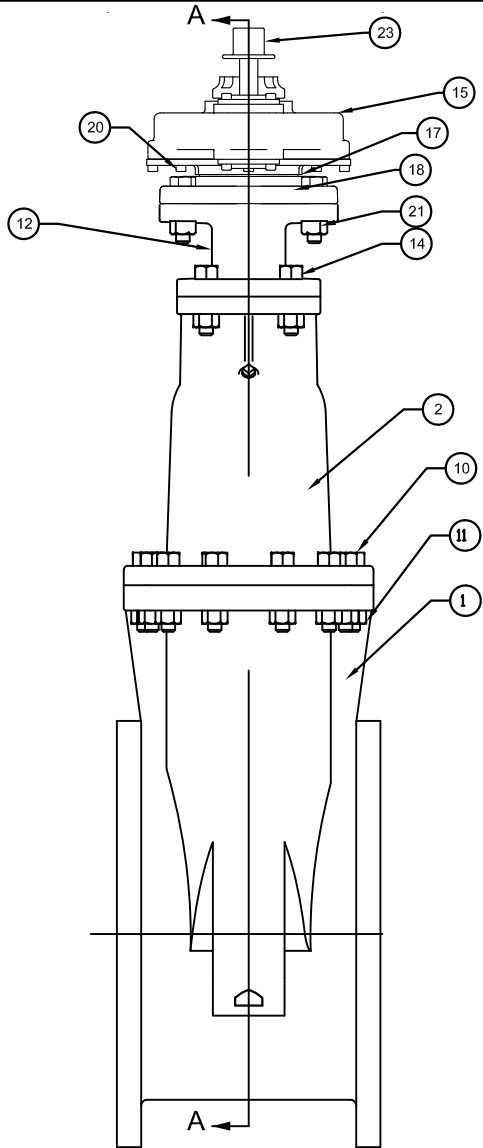

ITEM NO.	DESCRIPTION	MATERIAL	MATERIAL SPECIFICATION
1	Body	Ductile Iron	ASTM A536 65-45-12
2	Cover	Ductile Iron	ASTM A536 65-45-12
3	Wedge	Ductile Iron/Rubber	ASTM A536 65-45-12/SBR
4	Wedge Cap (18"-24" only)	Delrin	Delrin
5	O-ring	Rubber	NBR
6	Stem	Bronze	ASTM B584 C86700
7	Stem Nut	Bronze	ASTM B584 C86700
9	O-ring	Rubber	NBR
10	Hex Head Bolt	Stainless Steel	ASTM A307 Gr B
11	Hex Nut	Stainless Steel	ASTM A307 Gr B
12	Extension	Ductile Iron	ASTM A536 65-45-12
13	O-ring	Rubber	NBR
14	Hex Head Bolt	Stainless Steel	ASTM A307 Gr B
15	Actuator - 3:1 (18"-24") 2:1 (14-16")		
16	Adaptor Plate	Ductile Iron	ASTM A536 65-45-12
17	Actuator Gasket	Rubber	NBR
18	Socket Head Bolt	Alloy Steel	Alloy Steel
19	O-ring	Rubber	NBR
20	Hex Bolt	Stainless Steel	ASTM A307 Gr B
21	Hex Nut	Stainless Steel	ASTM A307 Gr B
22	Key	Steel	-----
23	Op Nut	Ductile Iron	ASTM A536 65-45-12
24	Pipe Plug - 1/2 NPT with square hd	Stainless Steel	AISI 304
25	Drive Sleeve	Steel	AISI 1023
26	Thrust Bearing	Delrin	-----
27	Thrust Bearing (18"-24" only)	Delrin	-----