

PROJECT
OWNER
CONTRACTOR
DISTRIBUTOR
CONSULTANT
CLOW CANADA

750mm-1200mm FLANGED RW GATE VALVE WITH SPUR GEAR
F6102 SG
FUSION EPOXY - NSF 61 & AWWA C515
COMPLIES WITH AWWA C509

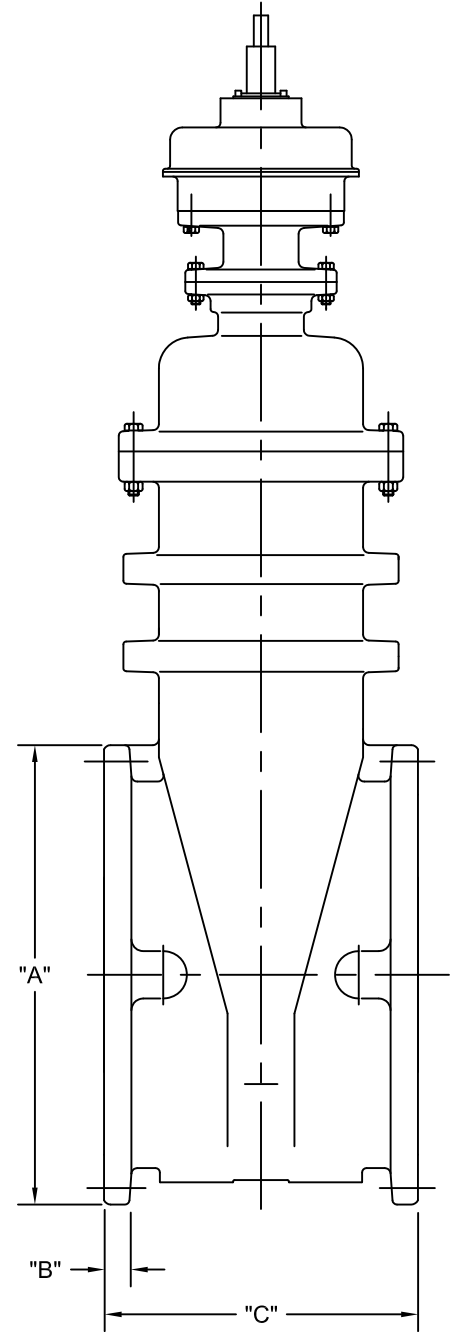
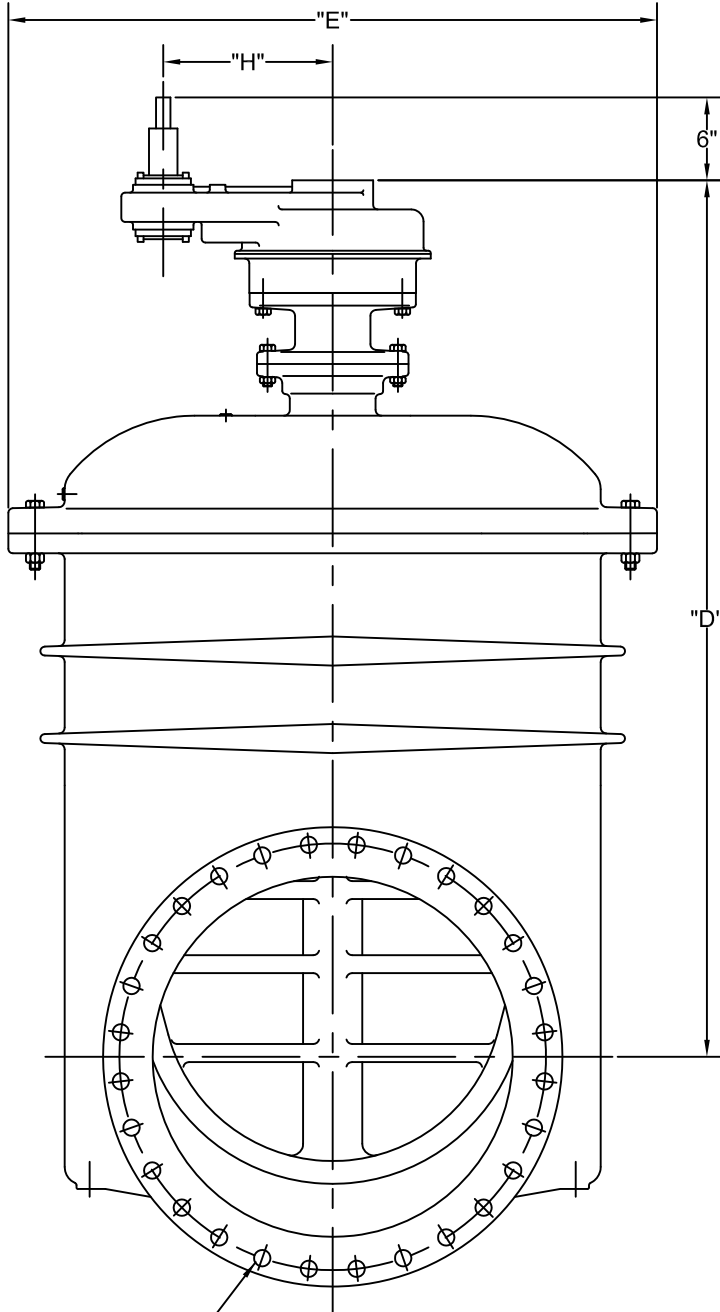

ANSI B16.1 Class 125 Drilling
for "F" # & "G" Size Bolts

Valve Size	"A"	"B"	"C"	"D"	"E"	"F"	"G"	"H"
750mm	984	54	673	1880	1390	28	1-1/4	356
900mm	1168	60	781	2126	1495	32	1-1/2	356
1050mm	1346	66	914	2604	1981	36	1-1/2	406
1200mm	1511	70	902	2680	1981	44	1-1/2	406